

# REGOLO SINGLE

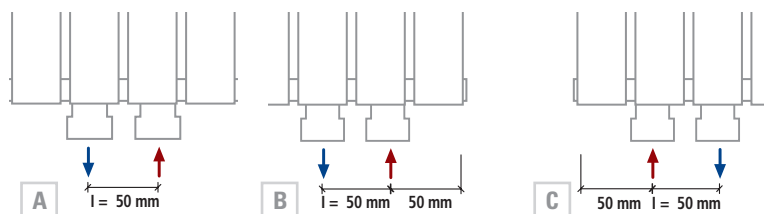
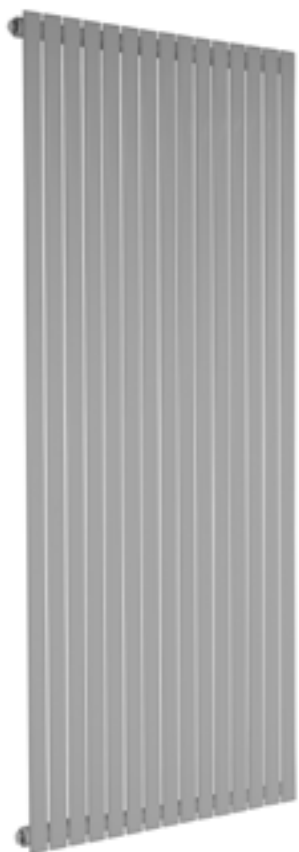
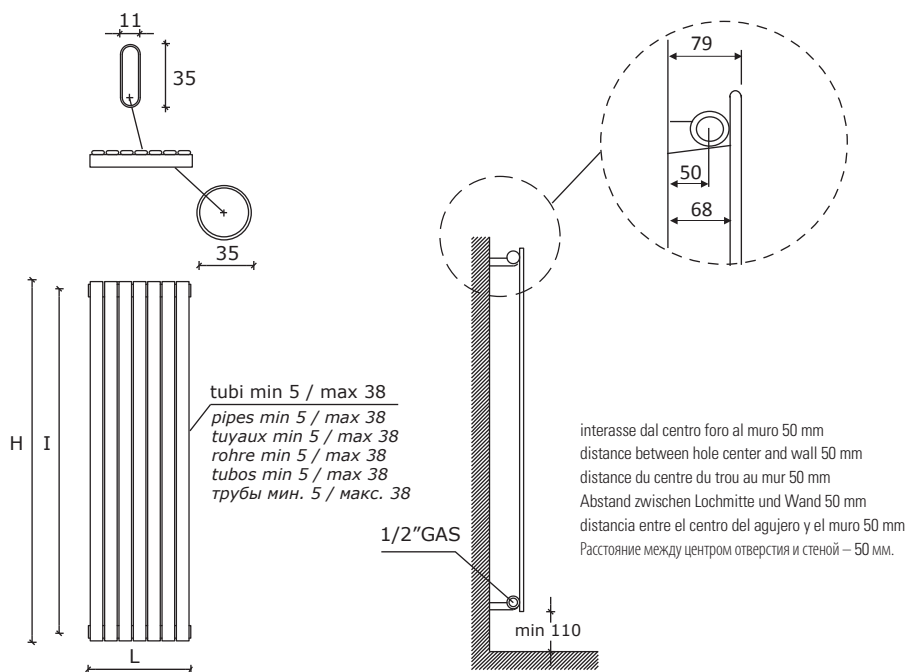

Interasse 50 mm a richiesta.  
Central distance 50 mm on request.  
Entraxe 50 mm sur demande.  
Mittelanschluss 50 mm Auf Anfrage.  
Distancia entre centros de 50 mm, bajo pedido.  
По запросу радиатор может выполняться с центральным межсекционным расстоянием, равным 50 мм.

Centrale, Central, Centrale,  
Mittel, Centrale, Центральный

Destro, Right, Droite, Recht,  
Derecha, Право

Sinistro, Left, Gauche, Links,  
Izquierda, Левый

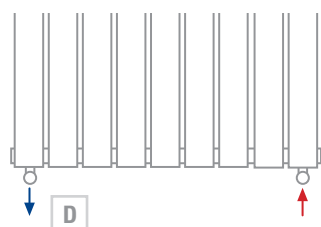

Allacciamenti dal basso a richiesta.  
Bottom connection on request.  
Branchement par dessous sur demande.  
Anschluss von unten Auf Anfrage.  
Conexión por abajo bajo pedido.  
Гидравлическое соединение снизу выполняется по запросу.

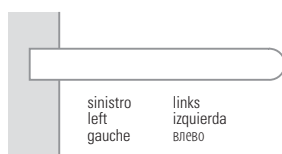

Barra portasciugamani short a richiesta. A partire da L 325.  
Short towel rail on request. From L 325.  
Barre porte-serviettes short sur demande. À partir de L 325.  
Handtuchtrockenstange Short Auf Anfrage. Ab Breite L = 325 mm.  
Barra calentatoallas short bajo pedido. A partir de L 325.  
По запросу изготавливается перекладина для полотенца модели Short.  
От длины L 325.



Regolo single è disponibile, per alcune misure, anche nelle versioni **solo elettrica** o in **versione mista**.  
Per informazioni consultare il ns ufficio tecnico tel. 0039 030 2530054.

Regolo single is available, for some measures, also in all **electric version** or in **dual energy version**.  
For information please contact our technical staff 0039 030 2530054.

Regolo single est disponible, pour des autres mesures, aussi en **version seulement électrique** ou en **version mixte**.  
Consulter notre bureau technique 0039 030 2530054.

Regolo single ist für einige Größen auch in **elektrischer Ausführung** lieferbar.  
Bitte kontaktieren Sie unsere technische Abteilung Tel.: 0039 030 2530054.

Regolo single es disponible, para algunas medidas, también en **version eléctrica** o en **version mixta**.  
Por información consulte con el departamento técnico 0039 030 2530054.

Рadiator Regolo single имеется в некоторых размерах, в смешанном или электрическом варианте.  
За дополнительной информацией обращаться в технический отдел (0039 030 2530054)

codice code code Artikel Nr. codigoo код	n° elementi no. des éléments Anzahl der Elemente no. elementos кол-во секций	larghezza width largeur Breite anchoo ширина	75/65-20 watt kcal/h Δt50	Watt = Kcal/h ÷ 0,860 Kcal/h = Watt × 0,860										altezza . height . hauteur . Höhe . altura . высота									
				H mm	H mm	H mm	H mm	H mm	H mm	H mm	H mm	H mm	H mm	H mm	H mm	H mm	H mm	H mm	H mm	H mm	H mm		
				interasse . distance between bars . entraxe . Achsabstand . distancia entre centros . межцентровое расстояние																			
				I mm	I mm	I mm	I mm	I mm	I mm	I mm	I mm	I mm	I mm	I mm	I mm	I mm	I mm	I mm	I mm				
				460	560	600	760	800	960	1160	1460	1760	1960	2160	2360								
RE05S...	5	205																					
			watt	131	154	162	197	206	240	282	345	408	451	493	536								
RE06S...	6	245																					
			watt	157	184	194	236	247	287	338	414	490	541	592	643								
RE07S...	7	285																					
			watt	183	215	227	275	288	335	394	483	571	631	690	750								
RE08S...	8	325																					
			watt	210	246	259	314	329	383	450	552	653	721	789	858								
RE09S...	9	365																					
			watt	236	276	292	354	370	431	507	621	734	811	887	965								
RE10S...	10	405																					
			watt	262	307	324	393	411	479	563	690	816	901	986	1072								
RE11S...	11	445																					
			watt	288	338	356	432	452	527	619	759	898	991	1085	1179								
RE12S...	12	485																					
			watt	314	368	389	472	493	575	676	828	979	1081	1183	1286								
RE13S...	13	525																					
			watt	341	399	421	511	534	623	732	897	1061	1171	1282	1394								
RE14S...	14	565																					
			watt	367	430	454	550	575	671	788	966	1142	1261	1380	1501								
RE15S...	15	605																					
			watt	393	461	486	590	617	719	845	1035	1224	1352	1479	1608								
RE16S...	16	645																					
			watt	419	491	518	629	658	766	901	1104	1306	1442	1578	1715								
RE17S...	17	685																					
			watt	445	522	551	668	699	814	957	1173	1387	1532	1676	1822								
RE18S...	18	725																					
			watt	472	553	583	707	740	862	1013	1242	1469	1622	1775	1930								
RE20S...	20	805																					
			watt	524	614	648	786	822	958	1126	1380	1632	1802	1972	2144								
RE22S...	22	885																					
			watt	576	675	713	865	904	1054	1239	1518	1795	1982	2169	2358								
RE24S...	24	965																					
			watt	629	737	778	943	986	1150	1351	1656	1958	2162	2366	2573								
RE26S...	26	1045																					
			watt	681	798	842	1022	1069	1245	1464	1794	2122	2343	2564	2787								
RE28S...	28	1125																					
			watt	734	860	907	1100	1151	1341	1576	1932	2285	2523	2761	3002								
RE30S...	30	1205																					
			watt	786	921	972	1179	1233	1437	1689	2070	2448	2703	2958	3216								
RE32S...	32	1285																					
			watt	838	982	1037	1258	1315	1533	1802	2208	2611	2883	3155	3430								
RE34S...	34	1365																					
			watt	891	1044	1102	1336	1397	1629	1914	2346	2774	3063	3352	3645								
RE36S...	36	1445																					
			watt	943	1105	1166	1415	1480	1724	2027	2484	2938	3244	3550	3859								
RE38S...	38	1525																					
			watt	996	1167	1231	1493	1562	1820	2139	2622	3101	3424	3747	4074								

**Materiale: acciaio al carbonio.**  
Pressione di esercizio: 8 bar

**Material: carbon-steel.**  
Working pressure: 8 bar

**Matériel: Acier.**  
Pression d'exercice: 8 bars

**Material: Kohlenstoffstahl.**  
Betriebsdruck: 8 bar

**Materia: Acero de carbono.**  
Presión de trabajo: 8 bar

**Материал – углеродистая сталь.**  
Рабочее давление – 8 бар

**Solo per i radiatori indicati è possibile, su richiesta, l'adattamento all'impianto monotubo.**  
La lavorazione speciale comporta un aumento del +10% dal prezzo.

**Only these radiators can be fitted for monotube connection on request.**

For these special processing a +10% increase on price is required.

**Seulement pour les radiateurs indiqués il est possible de prévoir sur demande l'adaptation pour la version monotube.**  
Pour cette opération il faut considérer une augmentation de 10% sur le prix.

**Nur die angegebenen Heizkörper können auf Anfrage für den Anschluss zum Einrohrsystem gefertigt werden.**  
Für diese Sonderbearbeitung ist eine Preiserhöhung von den 10 % vorgesehen.

**Sólo para estos radiadores es posible, bajo pedido, la adaptación para el sistema de calefacción monotubo.**  
Para este tratamiento especial se produce un aumento del + 10% desde el precio.

**Только эти радиаторы могут быть установлены с однотрубным подключением по запросу.**  
Эта специальная опция увеличивает цену на 10%.

# REGOLO DOUBLE

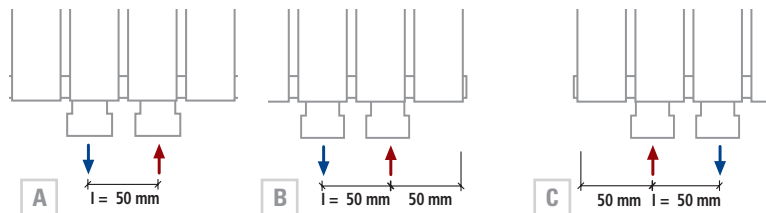
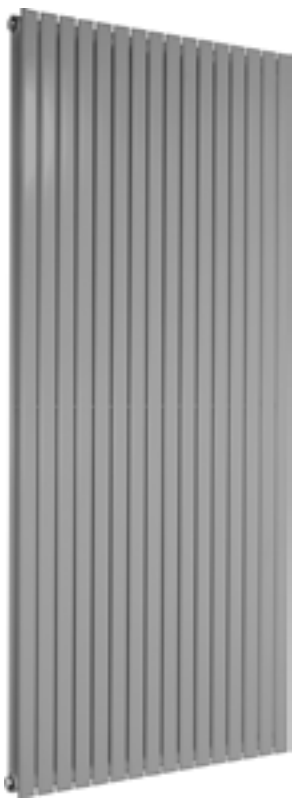
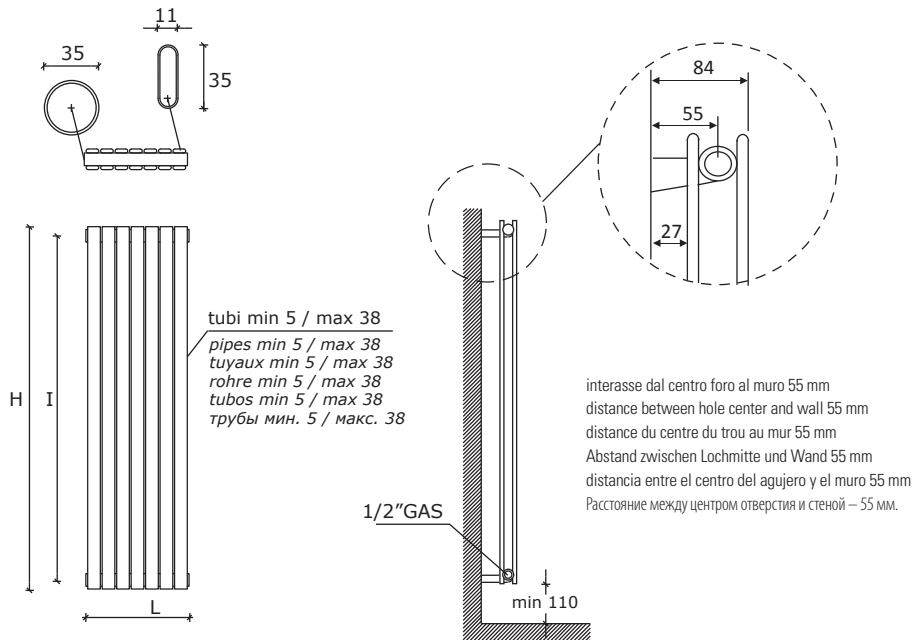

Centrale, Central, Centrale,  
Mittel, Centrale, Центральный

Destro, Right, Droite, Recht,  
Derecha, Право

Sinistro, Left, Gauche, Links,  
Izquierda, Левый

Interasse 50 mm a richiesta.  
Central distance 50 mm on request.  
Entraxe 50 mm sur demande.  
Mittelanschluss 50 mm Auf Anfrage.  
Distancia entre centros de 50 mm, bajo pedido.  
По запросу радиатор может выполняться с центральным межсексовым расстоянием, равным 50 мм.

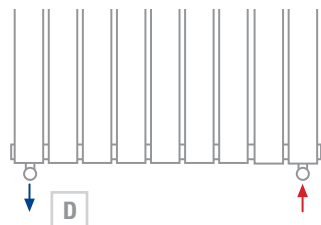

Allacciamenti dal basso a richiesta.  
Bottom connection on request.  
Branchement par dessous sur demande.  
Anschluss von unten Auf Anfrage.  
Conexión por abajo bajo pedido.  
Гидравлическое соединение снизу выполняется по запросу.

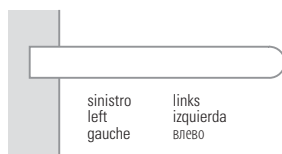

Barra portasciugamani short a richiesta. A partire da L 325.  
Short towel rail on request. From L 325.  
Barre porte-serviettes short sur demande. À partir de L 325.  
Handtuchtrockenstange Short Auf Anfrage. Ab Breite L = 325 mm.  
Barra calentatoallas short bajo pedido. A partir de L 325.  
По запросу изготавливается перекладина для полотенца модели Short. От длины L 325.

codice code Artikel Nr. codigo код	n° elementi no. des éléments Anzahl der Elemente no. elementos кол-во секций	larghezza width largeur Breite anchò ширина	75/65-20 watt kcal/h Δt50	Watt = Kcal/h ÷ 0,860 Kcal/h = Watt × 0,860											
				altezza . height . hauteur . Höhe . altura . высота											
				H mm	H mm	H mm	H mm	H mm	H mm	H mm	H mm	H mm	H mm	H mm	H mm
interasse . distance between bars . entraxe . Achsabstand . distancia entre centros . межцентровое расстояние															
I mm															
460 560 600 760 800 960 1160 1460 1760 1960 2160 2360															
RE05D...	5	205													
			watt	199	232	245	296	308	358	418	508	597	656	715	774
RE06D...	6	245													
			watt	239	278	293	355	370	429	502	610	716	787	858	929
RE07D...	7	285													
			watt	279	324	342	414	431	501	585	711	836	918	1001	1084
RE08D...	8	325													
			watt	318	370	391	473	493	572	669	813	955	1050	1144	1238
RE09D...	9	365													
			watt	358	417	440	532	554	644	752	914	1075	1181	1287	1393
RE10D...	10	405													
			watt	398	463	489	591	616	715	836	1016	1194	1312	1430	1548
RE11D...	11	445													
			watt	438	509	538	650	678	787	920	1118	1313	1443	1573	1703
RE12D...	12	485													
			watt	478	556	587	709	739	858	1003	1219	1433	1574	1716	1858
RE13D...	13	525													
			watt	517	602	636	768	801	930	1087	1321	1552	1706	1859	2012
RE14D...	14	565													
			watt	557	648	685	827	862	1001	1170	1422	1672	1837	2002	2167
RE15D...	15	605													
			watt	597	695	734	887	924	1073	1254	1524	1791	1968	2145	2322
RE16D...	16	645													
			watt	637	741	782	946	986	1144	1338	1626	1910	2099	2288	2477
RE17D...	17	685													
			watt	677	787	831	1005	1047	1216	1421	1727	2030	2230	2431	2632
RE18D...	18	725													
			watt	716	833	880	1064	1109	1287	1505	1829	2149	2362	2574	2786
RE20D...	20	805													
			watt	796	926	978	1182	1232	1430	1672	2032	2388	2624	2860	3096
RE22D...	22	885													
			watt	876	1019	1076	1300	1355	1573	1839	2235	2627	2886	3146	3406
RE24D...	24	965													
			watt	955	1111	1174	1418	1478	1716	2006	2438	2866	3149	3432	3715
RE26D...	26	1045													
			watt	1035	1204	1271	1537	1602	1859	2174	2642	3104	3411	3718	4025
RE28D...	28	1125													
			watt	1114	1296	1369	1655	1725	2002	2341	2845	3343	3674	4004	4334
RE30D...	30	1205													
			watt	1194	1389	1467	1773	1848	2145	2508	3048	3582	3936	4290	4644
RE32D...	32	1285													
			watt	1274	1482	1565	1891	1971	2288	2675	3251	3821	4198	4576	4954
RE34D...	34	1365													
			watt	1353	1574	1663	2009	2094	2431	2842	3454	4060	4461	4862	5263
RE36D...	36	1445													
			watt	1433	1667	1760	2128	2218	2574	3010	3658	4298	4723	5148	5573
RE38D...	38	1525													
			watt	1512	1759	1858	2246	2341	2717	3177	3861	4537	4986	5434	5882

**Materiale: acciaio al carbonio.**  
Pressione di esercizio: 8 bar

**Material: carbon-steel.**  
Working pressure: 8 bar

**Matériel: Acier.**  
Pression d'exercice: 8 bars

**Material: Kohlenstoffstahl.**  
Betriebsdruck: 8 bar

**Materia: Acero de carbono.**  
Presión de trabajo: 8 bar

**Материал – углеродистая сталь.**  
Рабочее давление – 8 бар

**Solo per i radiatori indicati è possibile, su richiesta, l'adattamento all'impianto monotubo.**  
La lavorazione speciale comporta un aumento del +10% dal prezzo.

**Only these radiators can be fitted for monotube connection on request.**

For these special processing a +10% increase on price is required.

**Seulement pour les radiateurs indiqués il est possible de prévoir sur demande l'adaptation pour la version monotube.**  
Pour cette opération il faut considérer une augmentation de 10% sur le prix.

**Nur die angegebenen Heizkörper können auf Anfrage für den Anschluss zum Einrohrsystem gefertigt werden.**  
Für diese Sonderbearbeitung ist eine Preiserhöhung von den 10 % vorgesehen.

**Sólo para estos radiadores es posible, bajo pedido, la adaptación para el sistema de calefacción monotubo.**  
Para este tratamiento especial se produce un aumento del + 10% desde el precio.

**Только эти радиаторы могут быть установлены с однотрубным подключением по запросу.**  
Эта специальная опция увеличивает цену на 10%.

# REGOLO TRIPLE

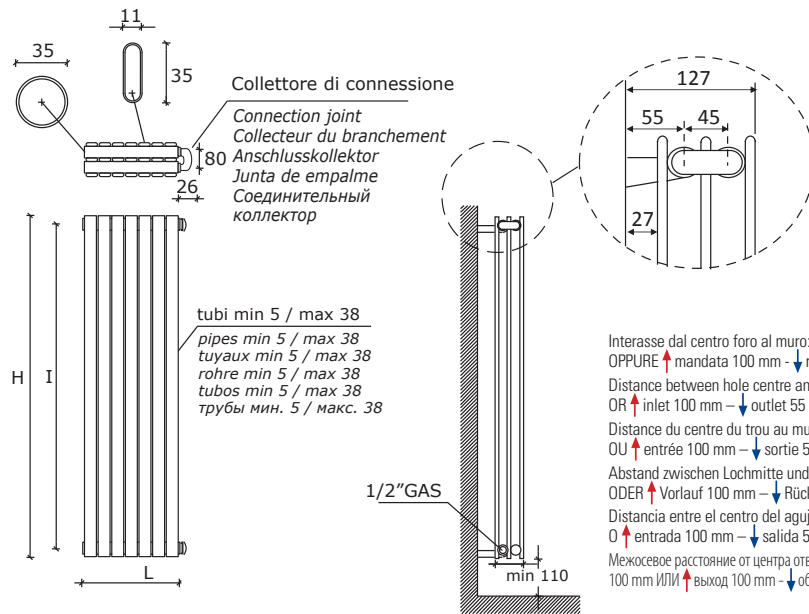

Interasse dal centro foro al muro: ↑ mandata 55 mm - ↓ ritorno 100 mm  
 OPPURE ↑ mandata 100 mm - ↓ ritorno 55 mm  
 Distance between hole centre and wall: ↑ inlet 55 mm - ↓ outlet 100 mm  
 OR ↑ inlet 100 mm - ↓ outlet 55 mm  
 Distance du centre du trou au mur: ↑ entrée 55 mm - ↓ sortie 100 mm  
 OU ↑ entrée 100 mm - ↓ sortie 55 mm  
 Abstand zwischen Lochmitte und Wand: ↑ Vorlauf 55 mm - ↓ Rücklauf 100 mm  
 ODER ↑ Vorlauf 100 mm - ↓ Rücklauf 55 mm  
 Distancia entre el centro del agujero y el muro: ↑ entrada 55 mm - ↓ salida 100 mm  
 O ↑ entrada 100 mm - ↓ salida 55 mm  
 Межшовное расстояние от центра отверстия до стены: ↑ выход 55 мм - ↓ обратная линия 100 мм ИЛИ ↑ выход 100 мм - ↓ обратная линия 55 мм

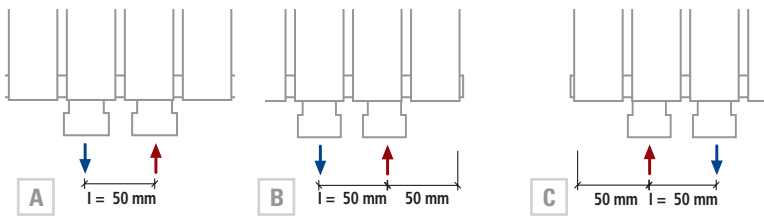
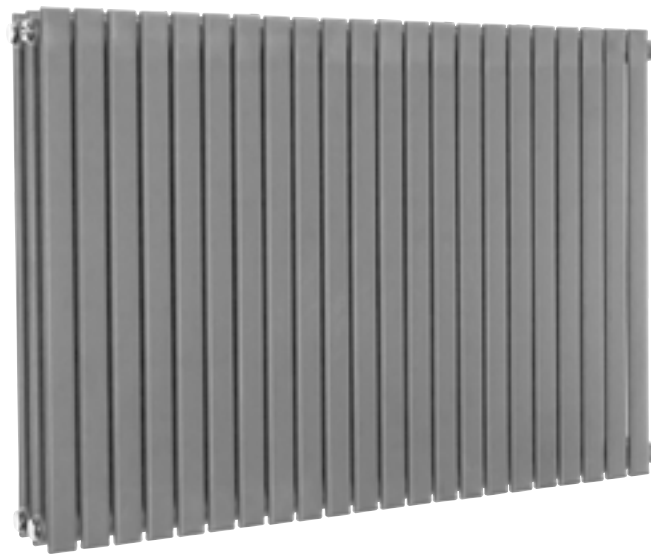

Centrale, Central, Centrale,  
Mittel, Centrale, Центральный

Destro, Right, Droite, Recht,  
Derecha, Право

Sinistro, Left, Gauche, Links,  
Izquierda, Левый

Interasse 50 mm a richiesta.  
 Central distance 50 mm on request.  
 Entraxe 50 mm sur demande.  
 Mittelschluss 50 mm Auf Anfrage.  
 Distancia entre centros de 50 mm, bajo pedido.  
 По запросу радиатор может выполняться с центральным межшовным расстоянием, равным 50 мм.

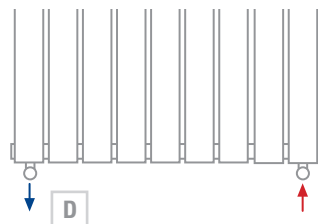

Allacciamenti dal basso a richiesta.  
 Bottom connection on request.  
 Branchement par dessous sur demande.  
 Anschluss von unten Auf Anfrage.  
 Conexión por abajo bajo pedido.  
 Гидравлическое соединение снизу выполняется по запросу.

codice code Artikel Nr. codigo код	n° elementi no. des éléments Anzahl der Elemente no. elementos кол-во секций	larghezza width largeur Breite ancho ширина  L mm	75/65-20 watt kcal/h Δt50	Watt = Kcal/h ÷ 0,860 Kcal/h = Watt × 0,860											
				altezza . height . hauteur . Höhe . altura . высота											
				H mm	H mm	H mm	H mm	H mm	H mm	H mm	H mm	H mm	H mm	H mm	H mm
				510	610	650	810	850	1010	1210	1510	1810	2010	2210	2410
				interasse . distance between bars . entreaxe . Achsabstand . distancia entre centros . межцентровое расстояние											
				I mm	I mm	I mm	I mm	I mm	I mm	I mm	I mm	I mm	I mm	I mm	I mm
				460	560	600	760	800	960	1160	1460	1760	1960	2160	2360
RE05T...	5	231	watt♦	284	331	350	423	442	513	602	734	864	952	1039	1127
RE06T...	6	271	watt♦	341	397	420	508	530	616	722	880	1037	1142	1247	1352
RE07T...	7	311	watt♦	397	464	489	592	618	719	842	1027	1210	1332	1454	1577
RE08T...	8	351	watt♦	454	530	559	677	707	821	963	1174	1383	1523	1662	1803
RE09T...	9	391	watt♦	511	596	629	762	795	924	1083	1320	1556	1713	1870	2028
RE10T...	10	431	watt♦	568	662	699	846	883	1027	1203	1467	1729	1903	2078	2253
RE11T...	11	471	watt♦	624	728	769	931	972	1130	1323	1614	1901	2093	2286	2479
RE12T...	12	511	watt♦	681	795	839	1015	1060	1232	1444	1761	2074	2284	2493	2704
RE13T...	13	551	watt♦	738	861	909	1100	1148	1335	1564	1907	2247	2474	2701	2929
RE14T...	14	591	watt♦	795	927	979	1185	1237	1438	1684	2054	2420	2664	2909	3154
RE15T...	15	631	watt♦	851	993	1049	1269	1325	1540	1805	2201	2593	2855	3117	3380
RE16T...	16	671	watt♦	908	1060	1119	1354	1413	1643	1925	2347	2766	3045	3324	3605
RE17T...	17	711	watt♦	965	1126	1189	1439	1501	1746	2045	2494	2939	3235	3532	3830
RE18T...	18	751	watt♦	1022	1192	1259	1523	1590	1848	2166	2641	3111	3426	3740	4056
RE20T...	20	831	watt♦	1135	1324	1398	1692	1766	2054	2406	2934	3457	3806	4156	4506
RE22T...	22	911	watt♦	1249	1457	1538	1862	1943	2259	2647	3228	3803	4187	4571	4957
RE24T...	24	991	watt♦	1362	1589	1678	2031	2120	2464	2888	3521	4149	4568	4987	5408
RE26T...	26	1071	watt♦	1476	1722	1818	2200	2296	2670	3128	3815	4494	4948	5402	5858
RE28T...	28	1151	watt♦	1589	1854	1958	2369	2473	2875	3369	4108	4840	5329	5818	6309
RE30T...	30	1231	watt♦	1703	1987	2098	2539	2650	3081	3609	4401	5186	5710	6233	6760
RE32T...	32	1311	watt♦	1816	2119	2237	2708	2826	3286	3850	4695	5532	6090	6649	7210
RE34T...	34	1391	watt♦	1930	2251	2377	2877	3003	3491	4091	4988	5877	6471	7064	7661
RE36T...	36	1471	watt♦	2043	2384	2517	3046	3180	3697	4331	5282	6223	6851	7480	8112
RE38T...	38	1551	watt♦	2157	2516	2657	3216	3356	3902	4572	5575	6569	7232	7895	8562

♦ I watt hanno valori provvisori in attesa di certificazione Δt50.

♦ The watt values are not definitive awaiting for Δt50 certification.

♦ Le nombre de Watts est une valeur indiquée à titre provisoire dans l'attente de la certification Δt50.

♦ Die Wattwerte sind noch provisorisch in Erwartung von Δt50 Zertifizierung.

♦ Los Vativos tienen valores provisionales en espera de la certificación Δt50.

♦ До получения сертификата Δt50 приводится предварительное значение мощности в ваттах.

**Materiale: acciaio al carbonio.**  
Pressione di esercizio: 4 bar  
♦ I watt hanno valori provvisori in attesa di certificazione Δt50.

**Material: carbon-steel.**  
Working pressure: 4 bar  
♦ The watt values are not definitive awaiting for Δt50 certification.

**Matériel: Acier.**  
Pression d'exercice: 4 bars  
♦ Le nombre de Watts est une valeur indiquée à titre provisoire dans l'attente de la certification Δt50.

**Material: Kohlenstoffstahl.**  
Betriebsdruck: 4 bar  
♦ Die Wattwerte sind noch provisorisch in Erwartung von Δt50 Zertifizierung.

**Materiale: Acero de carbono.**  
Presión de trabajo: 4 bar  
♦ Los Vativos tienen valores provisionales en espera de la certificación Δt50.

**Материал – углеродистая сталь.**  
Рабочее давление – 4 бар  
♦ До получения сертификата Δt50 приводится предварительное значение мощности в ваттах.